

SCXI™-1334 4 × 64 MATRIX TERMINAL BLOCK

This guide describes how to make signal connections, install the SCXI-1334 terminal block, and use the matrix expansion plug with your SCXI-1129 module. Refer to the *SCXI-1129 User Manual* for more detailed information about using the SCXI-1334 terminal block with the SCXI-1129 module.

Introduction

The SCXI-1334 is one of six terminal blocks you can install in front of the SCXI-1129 module. These terminal blocks allow you to easily turn the SCXI-1129 module into any of these high-density matrix configurations shown in Table 1:

Table 1. Terminal Block Matrix Configuration

Terminal Block	Matrix Configuration	Quantity of Matrixes
SCXI-1333	4 × 16	4
SCXI-1337	8 × 16	2
SCXI-1339	4 × 32	2
SCXI-1334	4 × 64	1
SCXI-1335	8 × 32	1
SCXI-1336	16 × 16	1



Note Common matrix terminology describes matrixes by the number of rows by the number of columns they contain. For example, four rows by 16 columns would be written as 4 × 16.

You can use the SCXI-1334 terminal block with the SCXI-1129 module to create a 4 × 64 matrix without any extra wiring except for connecting your signals to the rows and columns of the matrix. You can also combine the rows and/or columns to create many different matrix configurations. Using

the matrix expansion plugs, you can connect multiple modules to create matrixes with more rows. Using the row expansion cables, you can connect multiple modules to create matrixes with more columns. For example, connecting two modules gives you a 4×128 matrix.

The SCXI-1334 terminal block has screw terminals that provide access to the 4×64 matrix. Also, there are connections for scanner advanced and external trigger signals. The top and bottom 128-pin DIN connectors are for connecting columns between modules. The 10-pin DIN headers are for connecting rows between modules using matrix expansion cables.

Visit ni.com/instruments for information on other switching solutions.

Conventions



The following conventions are used in this guide:

This icon denotes a note, which alerts you to important information.



This icon denotes a caution, which advises you of precautions to take to avoid injury, data loss, or a system crash.

italic

Italic text denotes variables, emphasis, a cross reference, or an introduction to a key concept. This font also denotes text that is a placeholder for a word or value that you must supply.

monospace

Text in this font denotes text or characters that you should enter from the keyboard, sections of code, programming examples, and syntax examples. This font is also used for the proper names of disk drives, paths, directories, programs, subprograms, subroutines, device names, functions, operations, variables, filenames and extensions, and code excerpts.

Getting Started

To set up and use your SCXI-1334 terminal block, you need the following items:

- SCXI-1334 terminal block
- This document
- SCXI chassis
- SCXI-1129 module
- SCXI-1129 User Manual*

- Number 1 and 2 Phillips-head screwdrivers
- 1/8 in. flathead screwdriver
- Long-nose pliers
- Wire cutter
- Wire insulation stripper

Safety Information

The following cautions contain important safety information concerning hazardous voltages.



Cautions Do *not* operate the device in an explosive atmosphere or where there may be flammable gases or fumes.

Keep away from live circuits. Do *not* remove equipment covers or shields unless you are trained to do so. If signal wires are connected to the device, hazardous voltages can exist even when the equipment is turned off. To avoid a shock hazard, do *not* perform procedures involving cover or shield removal unless you are qualified to do so and disconnect all field power prior to removing covers or shields.

Equipment described in this document must be used in an Installation Category I¹ environment per IEC 60664-1. This category requires local level supply mains-connected installation.

Do *not* operate damaged equipment. The safety protection features built into this device can become impaired if the device becomes damaged in any way. If the device is damaged, turn the device off and do *not* use it until service-trained personnel can check its safety. If necessary, return the device to National Instruments for service and repair to ensure that its safety is not compromised.

Do *not* operate this equipment in a manner that contradicts the information specified in this document. Misuse of this equipment could result in a shock hazard.

Do *not* substitute parts or modify equipment. Because of the danger of introducing additional hazards, do *not* install unauthorized parts or modify the device. Return the device to National Instruments for service and repair to ensure that its safety features are not compromised.

You *must* insulate all of your signal connections to the highest voltage with which the SCXI-1334 can come in contact.

¹ Category I refers to a signal level such as voltages of an isolation transformer secondary on a PWB.

When using the device with high common-mode voltages, you *must* insulate your signal wires for the highest input voltage. National Instruments is *not* liable for any damages or injuries resulting from inadequate signal wire insulation. Use only 26-20 AWG wire with a minimum voltage rating of 150 V and a temperature value of 60 °C for measuring up to 150 V.

When connecting or disconnecting signal lines to the SCXI terminal block screw terminals, make sure the lines are powered off. Potential differences between the lines and the SCXI ground can create a shock hazard while you connect the lines.

Connections, including power signals to ground and vice versa, that exceed any of the maximum signal ratings on the SCXI device can create a shock or fire hazard, or can damage any or all of the boards connected to the SCXI chassis, the host computer, and the SCXI device. National Instruments is *not* liable for any damages or injuries resulting from incorrect signal connections.

If hazardous voltages ($\geq 30 V_{\text{rms}}$ and $42.4 V_{\text{peak}}$ or 60 VDC) are present, you *must* connect a safety earth-ground wire to the terminal block safety-ground lug, shown in Figure 1. This complies with safety agency requirements and protects against electric shock when the terminal block is not connected to the chassis. To connect the safety earth-ground to the safety-ground lug, run an earth-ground wire from the signal source to the terminal block. National Instruments is *not* liable for any damages or injuries resulting from inadequate safety earth-ground connections.

Do *not* loosen or re-orient the safety-ground lug hardware when connecting the safety-ground wire; to do so reduces the safety isolation between the high voltage and safety ground.

Clean the module and accessories by brushing off light dust with a soft non-metallic brush. Remove other contaminants with a stiff non-metallic brush. The unit *must* be completely dry and free from contaminants before returning it to service.

The terminal block *must* be used with a UL-listed SCXI chassis.

Unpacking

Your SCXI-1334 terminal block is shipped in an antistatic package to prevent electrostatic damage to the terminal block. Electrostatic discharge can damage several components on the terminal block. To avoid such damage in handling the terminal block, take the following precautions:

- Ground yourself using a grounding strap or by holding a grounded object.
- Touch the antistatic package to a metal part of your computer chassis before removing the terminal block from the package.



Caution *Never* touch the exposed pins of connectors.

Remove the terminal block from the package and inspect the terminal block for loose components or any sign of damage. Notify National Instruments if the terminal block appears damaged in any way. Do *not* install a damaged terminal block into your system.

Store your SCXI-1334 terminal block in the antistatic envelope when not in use.

Connecting Signals



Note Refer to the [Safety Information](#) section before removing equipment covers or connecting or disconnecting any signal wires.

To connect the signal(s) to the terminal block, perform the following steps, referring to Figures 1 and 2 as necessary:

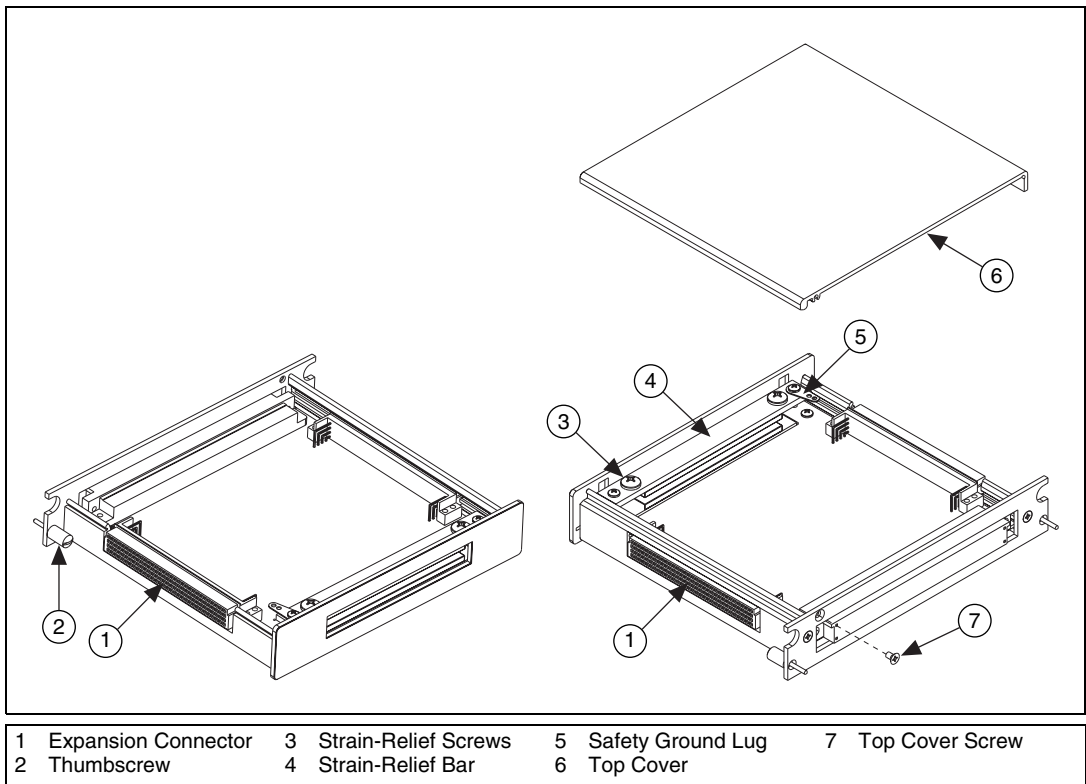
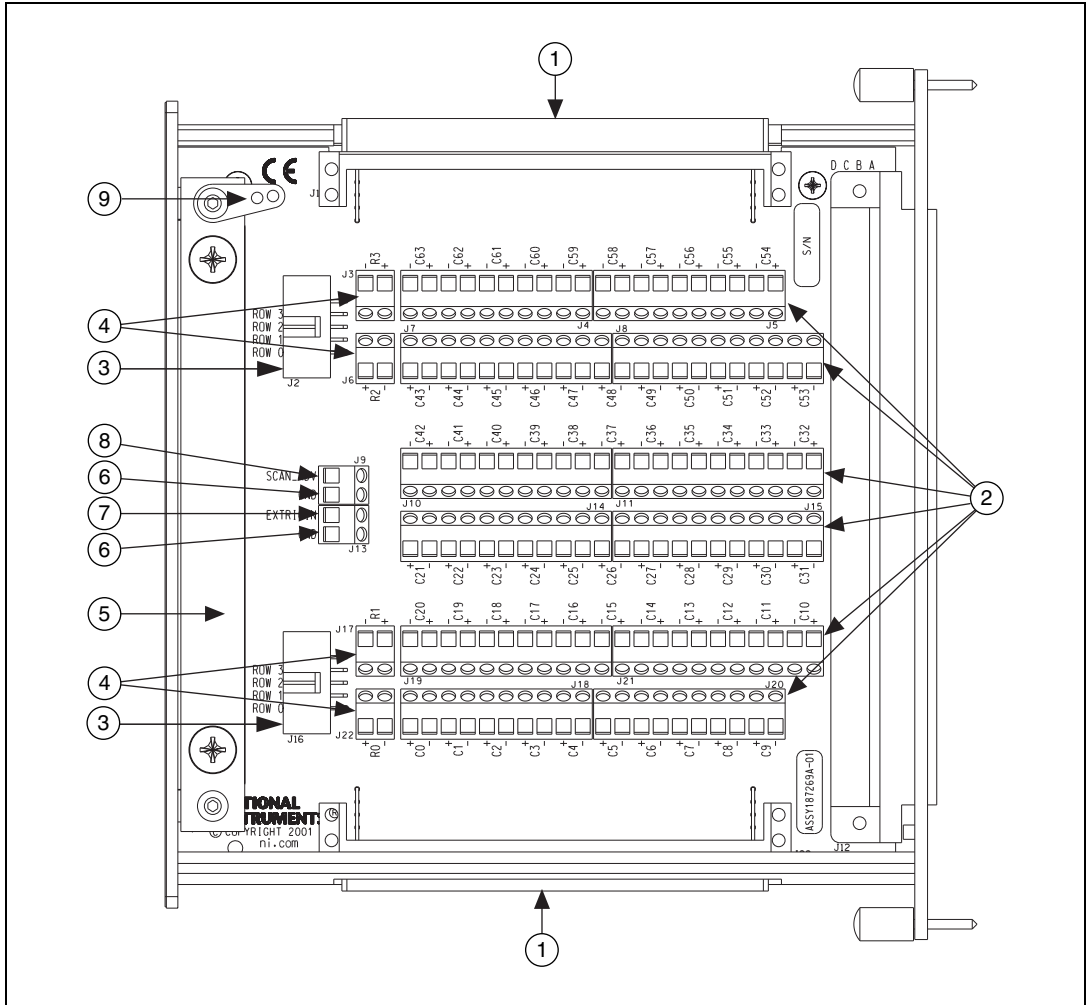

Figure 1. SCXI-1334 Parts Locator Diagram

1. Remove the top cover screw.
2. Unsnap and remove the top cover.
3. Loosen the strain-relief screws.
4. Run the signal wires through the strain-relief opening. You can add insulation or padding if necessary.
5. Prepare your signal wire by stripping the insulation no more than 7 mm.
6. Connect the wires to the screw terminals by inserting the stripped end of the wire fully into the terminal. No bare wire should extend past the screw terminal. Exposed wire increases the risk of a short-circuit causing a failure.

When connecting your signals to the SCXI-1334, follow the labeling on the SCXI-1334 as indicated in Figures 2 and 3.



- | | |
|--------------------------------------|--|
| 1 Matrix Expansion Buses | 6 Ground Reference for Trigger Signals Screw Terminals |
| 2 Column Connections Screw Terminals | 7 External Trigger Input (EXTRIGIN) Screw Terminal |
| 3 Row Expansion Buses | 8 Scanner Advanced Output (SCAN ADV) Spring Terminal |
| 4 Row Connections Screw Terminals | 9 Safety Ground Lug |
| 5 Strain-Relief Bar | |

Figure 2. SCXI-1334 Signal Connections

Pin Number	Signal Name	Column				Signal Name
		A	B	C	D	
32	C31-	○	○	○	○	C63-
	C31+	○	○	○	○	C63+
31	C30-	○	○	○	○	C62-
	C30+	○	○	○	○	C62+
30	C29-	○	○	○	○	C61-
	C29+	○	○	○	○	C61+
29	C28-	○	○	○	○	C60-
	C28+	○	○	○	○	C60+
28	C27-	○	○	○	○	C59-
	C27+	○	○	○	○	C59+
27	C26-	○	○	○	○	C58-
	C26+	○	○	○	○	C58+
26	C25-	○	○	○	○	C57-
	C25+	○	○	○	○	C57+
25	C24-	○	○	○	○	C56-
	C24+	○	○	○	○	C56+
24	C23-	○	○	○	○	C55-
	C23+	○	○	○	○	C55+
23	C22-	○	○	○	○	C54-
	C22+	○	○	○	○	C54+
22	C21-	○	○	○	○	C53-
	C21+	○	○	○	○	C53+
21	C20-	○	○	○	○	C52-
	C20+	○	○	○	○	C52+
20	C19-	○	○	○	○	C51-
	C19+	○	○	○	○	C51+
19	C18-	○	○	○	○	C50-
	C18+	○	○	○	○	C50+
18	C17-	○	○	○	○	C49-
	C17+	○	○	○	○	C49+
17	C16-	○	○	○	○	C48-
	C16+	○	○	○	○	C48+
16	C15-	○	○	○	○	C47-
	C15+	○	○	○	○	C47+
15	C14-	○	○	○	○	C46-
	C14+	○	○	○	○	C46+
14	C13-	○	○	○	○	C45-
	C13+	○	○	○	○	C45+
13	C12-	○	○	○	○	C44-
	C12+	○	○	○	○	C44+
12	C11-	○	○	○	○	C43-
	C11+	○	○	○	○	C43+
11	C10-	○	○	○	○	C42-
	C10+	○	○	○	○	C42+
10	C9-	○	○	○	○	C41-
	C9+	○	○	○	○	C41+
9	C8-	○	○	○	○	C40-
	C8+	○	○	○	○	C40+
8	C7-	○	○	○	○	C39-
	C7+	○	○	○	○	C39+
7	C6-	○	○	○	○	C38-
	C6+	○	○	○	○	C38+
6	C5-	○	○	○	○	C37-
	C5+	○	○	○	○	C37+
5	C4-	○	○	○	○	C36-
	C4+	○	○	○	○	C36+
4	C3-	○	○	○	○	C35-
	C3+	○	○	○	○	C35+
3	C2-	○	○	○	○	C34-
	C2+	○	○	○	○	C34+
2	C1-	○	○	○	○	C33-
	C1+	○	○	○	○	C33+
1	C0-	○	○	○	○	C32-
	C0+	○	○	○	○	C32+

Figure 3. SCXI-1334 Matrix Expansion Bus Pinout

7. Connect the safety earth ground to the safety ground lug. Refer to the [Safety Information](#) section for connection information.
8. Tighten the strain-relief bar.
9. Reinstall the top cover.



Caution Only daisy-chain terminal blocks of the same type together. Daisy-chaining different types of terminal blocks together can cause damage to the module or to the equipment connected to the module. For example, you can daisy-chain two or more SCXI-1334 terminal blocks; however, do *not* daisy-chain the SCXI-1334 together with any other type of terminal block.

Installing the Terminal Block

To connect the terminal block to the SCXI module front connector, perform the following steps while referring to Figure 4:

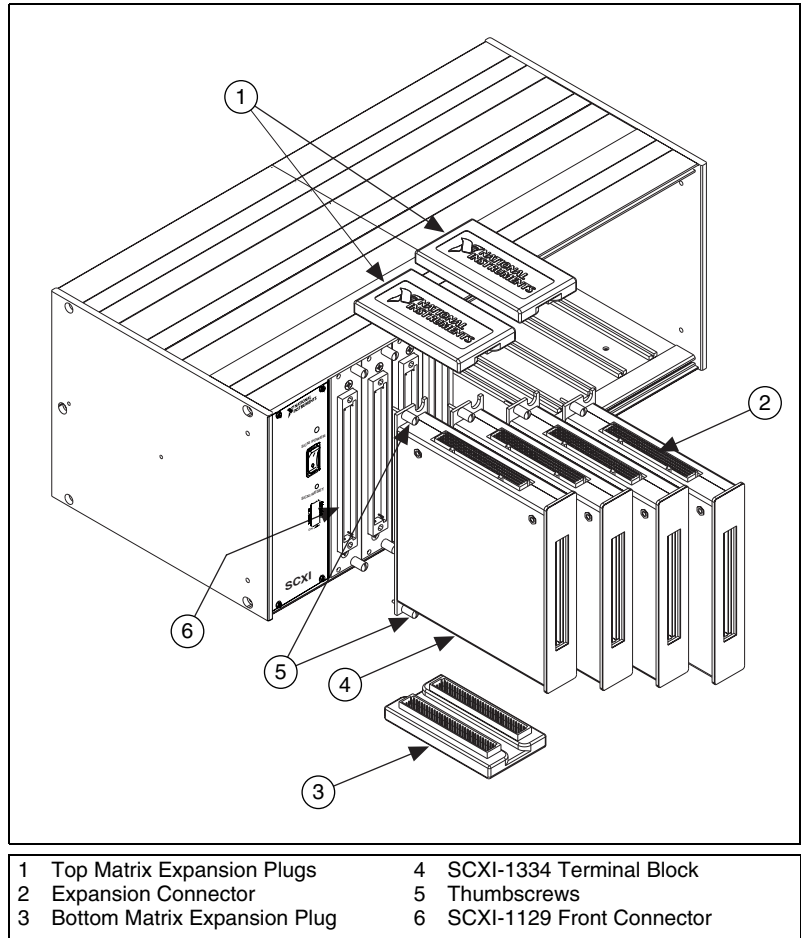

Figure 4. Terminal Block and Matrix Expansion Plug Installation

1. Connect the module front connector to its mating connector on the terminal block.
2. Tighten the top and bottom thumbscrews on the back of the terminal block to hold it securely in place.

The Matrix Expansion Plug

You can use the matrix expansion plug to connect the columns of adjacent terminal blocks creating larger matrixes. Use the matrix expansion plug to expand rows. For example, two 4×64 matrixes connected using the matrix expansion plug creates an 8×64 matrix. No external cabling is required.

Installing the Matrix Expansion Plug

To install the matrix expansion plug, complete the following steps while referring to Figures 4 and 5:

1. Align the matrix expansion plug over the top expansion connectors of two adjacent terminal blocks.
2. Press firmly, but gently, until matrix expansion plug is seated.
3. Align the matrix expansion plug over the bottom expansion connectors of two adjacent terminal blocks—skipping the first terminal block on which you placed the top matrix expansion plug.
4. Press firmly, but gently, until matrix expansion plug is seated.



Note The matrix expansion plugs are keyed and install in one direction only.

Removing the Matrix Expansion Plug

To remove the matrix expansion plug, complete the following steps while referring to Figure 5:

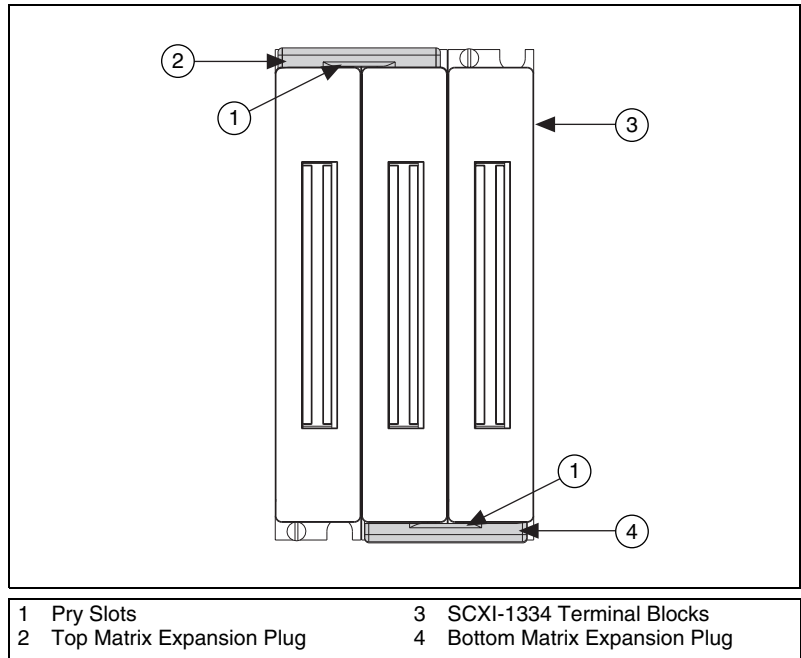

Figure 5. Removing the Matrix Expansion Plug

1. Place the tip of a flat blade screwdriver in the pry slot at the end of the matrix expansion plug.
2. Gently, pry the matrix expansion plug off the mating connectors.

Specifications

All specifications are typical at 25 °C unless otherwise specified.

Maximum Voltage

Terminal to earth150 V_{rms} or VDC

Terminal to terminal150 V_{rms} or VDC

Environment

Operating temperature0 to 50 °C

Storage temperature-20 to 70 °C

Relative humidity10 to 90%

Safety

Designed in accordance with IEC61010-1, UL 3111-1, and CAN/CSA C22.2 No. 1010.1 for electrical measuring and test equipment

For use at altitudes up to 2000 m

Indoor use only

Installation Category I

Pollution Degree 2

Emissions and Immunity

EMC/EMICE, C-Tick and FCC Part 15 (Class A) Complaint

Electrical emissionsEN 55011 Class A at 10 m;
FCC Part 15A above 1 GHz

Electrical immunityEvaluated to EN 61326:1998,
Table 1



Note For full EMC and EMI compliance, you must operate this device with shielded cabling. See the Declaration of Conformity (DoC) for this product for any additional regulatory compliance information. To obtain the DoC for this product, click **Declaration of Conformity** at ni.com/hardref.nsf. This website lists the DoCs by product family. Select the appropriate product family, followed by your product, and a link

to the DoC (in Adobe Acrobat format) appears. Click the Acrobat icon to download or read the DoC.

Technical Support Resources

NI Web Support

National Instruments Web support is your first stop for help in solving installation, configuration, and application problems and questions. Online problem-solving and diagnostic resources include frequently asked questions, knowledge bases, product-specific troubleshooting wizards, manuals, drivers, software updates, and more. Web support is available through the Technical Support section of ni.com

Worldwide Support

National Instruments has offices located around the world to help address your support needs. You can access our branch office Web sites from the Worldwide Offices section of ni.com. Branch office Web sites provide up-to-date contact information, support phone numbers, e-mail addresses, and current events.

If you have searched the technical support resources on our Web site and still cannot find the answers you need, contact your local office or National Instruments corporate. For telephone support in the United States, dial 512 795 8248. For telephone support outside the United States, contact your local branch office:

Australia 03 9879 5166, Austria 0662 45 79 90 0, Belgium 02 757 00 20,
Brazil 011 284 5011, Canada (Calgary) 403 274 9391,
Canada (Ottawa) 613 233 5949, Canada (Québec) 514 694 8521,
China (Shanghai) 021 6555 7838, China (ShenZhen) 0755 3904939,
Denmark 45 76 26 00, Finland 09 725 725 11, France 01 48 14 24 24,
Germany 089 741 31 30, Greece 30 1 42 96 427, Hong Kong 2645 3186,
India 91805275406, Israel 03 6120092, Italy 02 413091,
Japan 03 5472 2970, Korea 02 596 7456, Mexico 5 280 7625,
Netherlands 0348 433466, New Zealand 09 914 0488,
Norway 32 27 73 00, Poland 0 22 528 94 06, Portugal 351 1 726 9011,
Singapore 2265886, Spain 91 640 0085, Sweden 08 587 895 00,
Switzerland 056 200 51 51, Taiwan 02 2528 7227,
United Kingdom 01635 523545